

DOOSAN

www.doosaniv.com

7 Series Forklifts

Heavy Forklift 18 to 25 ton Series

EPA Tier IV / Euro Stage IV



Building your tomorrow today

GENERAL SPECIFICATION

CHARACTERISTICS					
2	Model			DV180S-7	DV250S-7
3	Capacity	at rated load center	kg	18,000	25,000
4	Load center	distance	mm	1,200	1,200
5	Power type	electric, diesel, gasoline, lp-gas		Diesel	Diesel
6	Operator type	stand-on, rider-seated		Rider-seated	Rider-seated
7	Tire	c=cushion, p=pneumatic		p	p
8	Wheels(x=driven)	number, front/rear		x4/2	x4/2
DIMENSIONS					
9	Lift with STD two-stage mast	maximum fork height	mm	3,500	4,000
10		free lift	mm	0	0
11	Forks	thickness x width x length	mm	100x250x2,400	110x250x2,400
12		forkspacing (minimum x maximum)		710-2,394	800-2,600
13	Tilt of mast	forward/backward	deg	10/9	12/10
14	Overall dimensions	length to fork face	mm	5,595	6,350
15		width	mm	2,540	3,050
16		mast lowered height	mm	3,485	3,850
17		mast extended height	mm	5,205	5,810
18		cab Height	mm	2,930	3,310
19		seat height	mm	1,800	2,150
20	Minimum outside turning radius		mm	5,120	5,950
21	Load moment constant		mm	1,000	1,120
22	90°stacking aisle	2400x2400	mm	8,720	9,670
	90°intersecting aisle		mm	4,690	5,460
PERFORMANCE					
23	Speed	travel, loaded/unloaded	km/h	39/42	37/40
24		lift, loaded/unloaded	mm/s	380/410	310/340
25		lowering, loaded/unloaded	mm/s	400/350	400/350
26	Drawbar pull	at 1.6km/h, loaded	kg	15,399/14,650	23,516/22,708
27	Gradeability	at 1.6km/h, loaded	%	35.6	36.0
WEIGHT					
28	Total weight	unloaded	kg	26,400	38,500
29	Axle load	with loaded, front/rear	kg	41,210/3,190	57,897/5,603
30		without loaded, front/rear	kg	12,650/13,750	19,250/19,250
CHASSIS					
31	Tires	number of front/rear		4/2	4/2
32		size, front single		12.00 R20	14.00-24"-28PR
33		size, rear		12.00 R20	14.00-24"-28PR
34	Wheel base		mm	3,750	4,250
35	Tread	front/rear	mm	1,858/1,976	2,200/2,140
36	Ground clearance	loaded, at the lowest point	mm	210	290
37		loaded, at center of wheelbase	mm	325	380
38	Brake	service		Disc	Disc
39		parking		Mechanical	Mechanical
DRIVE					
40	Battery	voltage/ampere-hour	V/AH	24(12x2) / 150	
41	Engine	manufacturer/model		Doosan / DLo8P	
42		rated output (DIN)	ps(kW)/rpm	250(183.7) / 2,100	290(213.3) / 2,100
43		max. torque	Nm/rpm	1,157/1,300	1,236/1,300
44		cycle/cylinders/displacement	cc	4/6/7,640	
45		Fuel Tank	l	300	400
46	DEF(AdBlue)	l	30	30	
47		manufacerur/model		ZF / 4WG211	ZF / 4WG211
48		Transmission Type		Full Autoshift	Full Autoshift
49		No. of speeds forward/reverse		4/3	4/3
50	Driveaxle			Kessler D81	Kessler D91
51	Operating pressure	system/attachment	bar	235/185	230/220

Note : Specification values quoted in this specification sheet has been rounded. Performance may vary due to operation conditions. Products and specifications are subject to improvement and change without prior notices.

DIMENSIONAL DRAWING

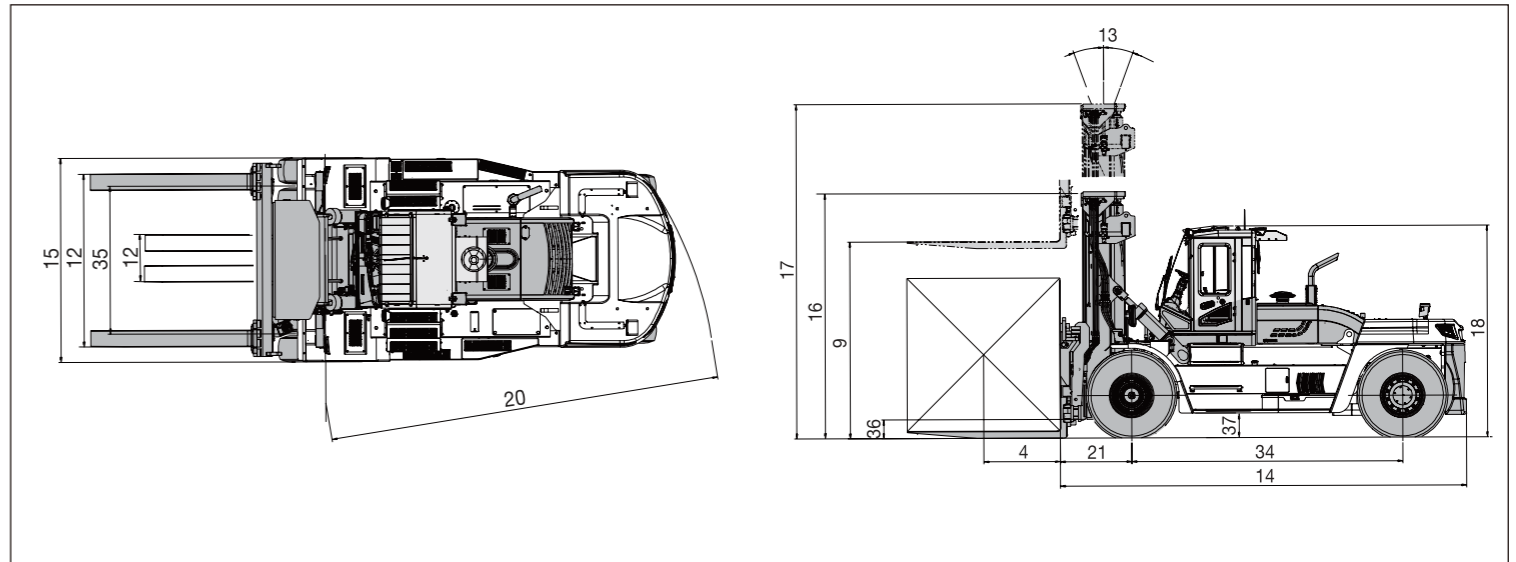

MAST SPECIFICATIONS and RATED CAPACITIES

DV180/250S-7

Model	Mast Type	Max. Fork Height		Mast Lowered Height		Extended Height		Free Lift		Rated Load Capacities			
		mm	in	mm	in	w/ Load Backrest		w/ Load Backrest		Tilt Angle		LC 1200mm	LC 48in
						mm	in	mm	in	deg	deg		
DV180S-7	STD	3000	118	3235	127	4705	185	0	0	10	9	18000	40000
		3500	138	3485	137	5205	205	0	0	10	9	18000	40000
		4500	177	3985	157	6205	244	0	0	10	9	18000	40000
		5000	197	4235	167	6705	264	0	0	10	9	18000	39500
	FFT	4500	177	2930	115	5920	233	1550	61	10	9	17000	37500
		5000	197	3100	122	6430	253	1720	68	10	9	17000	37500
DV250S-7	STD	3500	157	3600	142	5310	209	0	0	12	10	25000	55000
		4000	177	3850	152	5810	229	0	0	12	10	25000	55000
		5000	197	4350	171	6810	268	0	0	12	10	25000	55000
		5600	220	4650	183	7410	292	0	0	12	10	24815	54600
	FFT	4700	185	3400	134	6530	257	1590	63	12	10	25000	55000
		5000	197	3500	138	6830	269	1690	67	12	10	25000	55000
		5600	220	3700	146	7430	293	1890	74	12	10	24815	54600

Note : Mast Specifications & Rated Capacities are based on standard chassis with dual pneumatic tire and without side shifter.

DOOSAN

Doosan Industrial Vehicle Europe NV
Europark-Noord 36A
9100 Sint-Niklaas
Belgium

Website: www.doosaniv.com

MEAD(V)250S-7 Tier4-221219V1EN (December 2022)

Authorized Dealer